



Diaphragm Pump 21 Series

Features & Benefits

- Compact design
- Heavy-duty demand switch
- Can run dry
- Quiet operation
- Industry standard mount pattern

Typical Applications

- Marine/RV
- Water Treatment/Ro
- Beverage/Food Service
- Distillation Equipment
- Agricultural Spraying
- General Industrial
- Automotive

PUMP

- Type**
2 Chamber positive displacement diaphragm pump, self priming, capable of being run dry
- Max Recommended Temperature**
110°F (43°C) Max.
- Priming Capabilities**
4 feet (1.2 m) suction lift
- Max Pressure**
40PSI (2.8bar)
- Inlet/Outlet Ports**
3/8" hose barb
- Weight**
1.25 lbs (0.57 kg)

MOTOR

- Duty Cycle**
Intermittent
- Leads**
18 AWG, 13.78" long with 2-Pin connector/Leads
- Voltage**
12v/24v



21F001
360° swivel quick connector

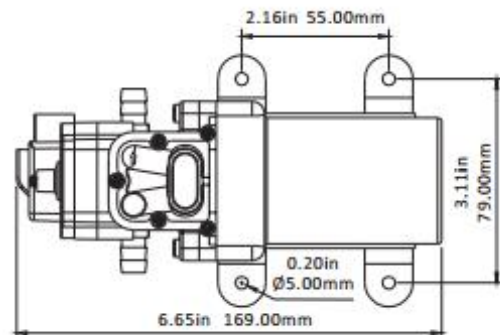
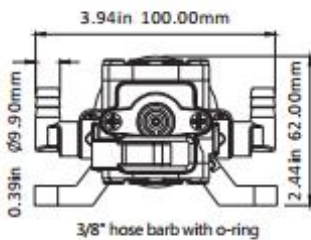
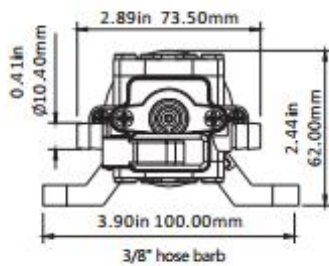

STANDARD PUMP CONFIGURATIONS

Model	GPM	Switch	Amps	PSI	Valves Viton	Diaphragm	Ports	Voltage	Wire Connections
SFDP1-010-040-21	1.0 GPM	Demand	4.0 MAX	40	EPDM	Santoprene	3/8" Barb	12V	2-Pin/Leads
SFDP2-010-040-21	1.0 GPM	Demand	2.0 MAX	40	EPDM	Santoprene	3/8" Barb	24V	2-Pin/Leads